

ZHH Ducktail

The entire installation process is divided into two parts:

1. The first part is to remove the original car's electric spoiler.
2. The second part is to install and secure the spoiler bracket.

First, we need to remove the original car's electric spoiler.

The electric spoiler is mainly divided into three parts as shown in the picture.

We need to follow the steps to remove the spoiler step by step.

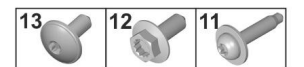
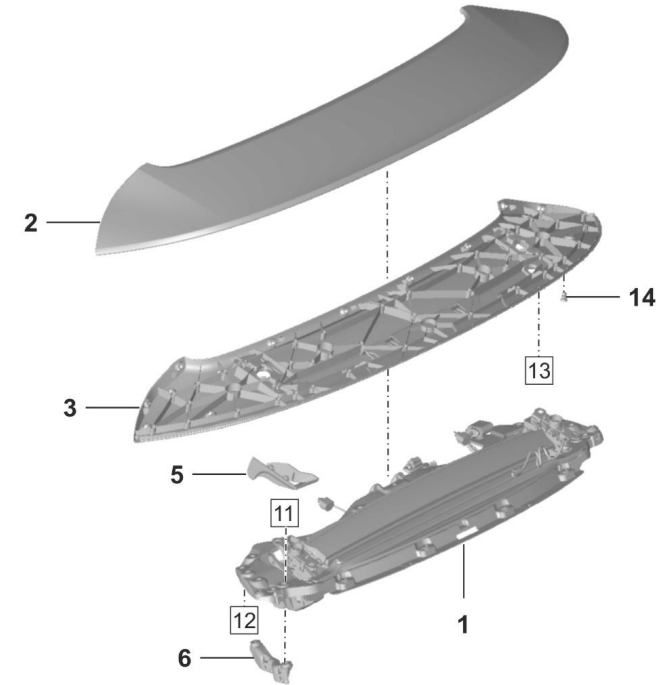

Step 1



Raise the electric spoiler.

Step 2



The top cover of the electric spoiler is secured by screws around it. Therefore, you need to remove the screws one by one as shown in the picture. After removing all the screws, two people can work together to remove the top cover.

Step 3

There are two screws on this part of the plastic cover that need to be removed.



The screws securing the cover on the backside are protected by a shield, so we need to use a screwdriver to remove the shield first.

Step 4



After removing the shield, we can take out the screws on the backside one by one, as shown in the picture.

Step 5



When removing this panel, be sure to disconnect the brake light plug

Step 6

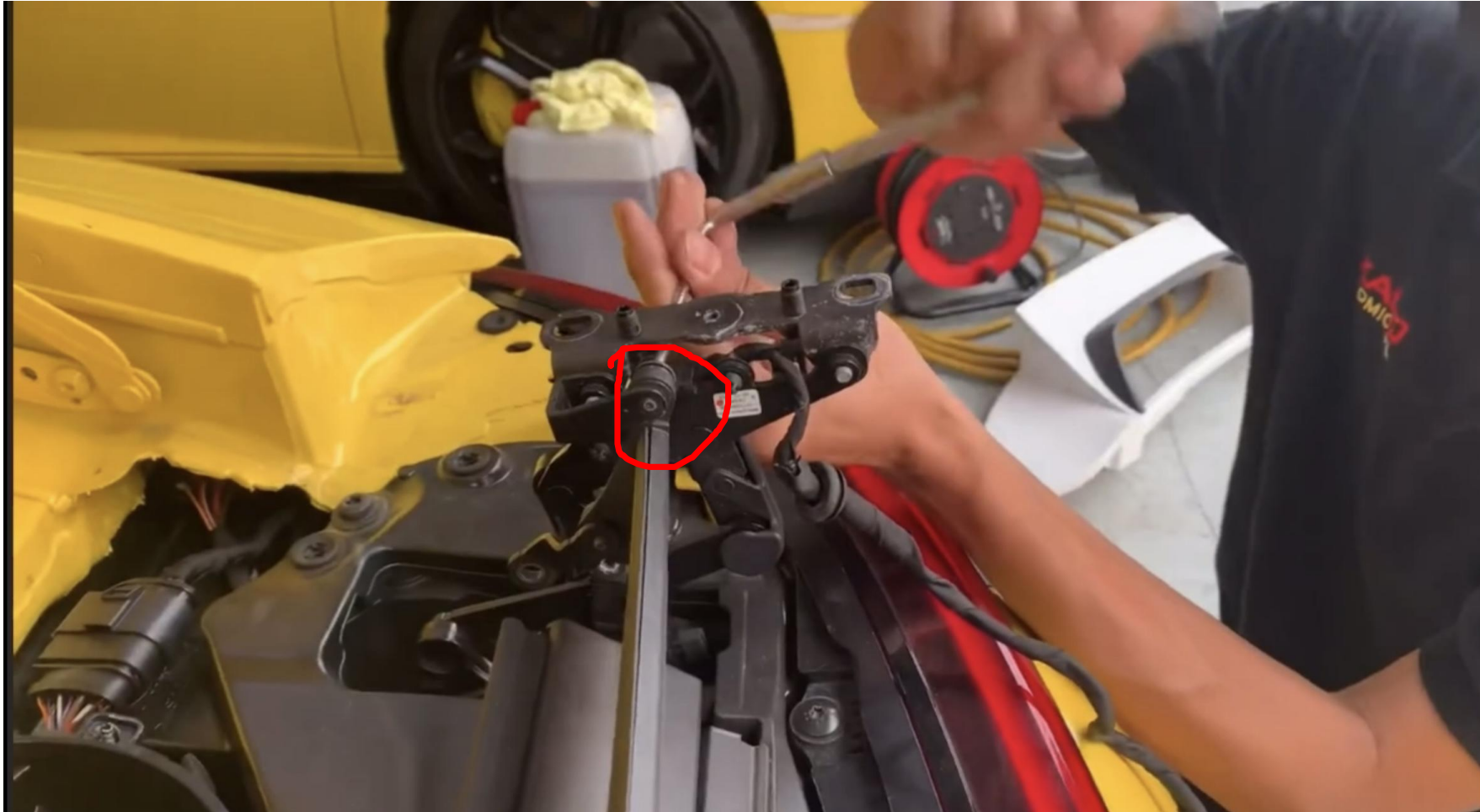

As shown in the picture, remove the screws that secure the upper part of the folding panel.

Step 7



Remove the six screws that secure the taillights one by one.

Step 8



Use a screwdriver to remove the lower part of the folding panel from the clips
Then remove the cooling fan to facilitate the movement of the tail base.

Step 9

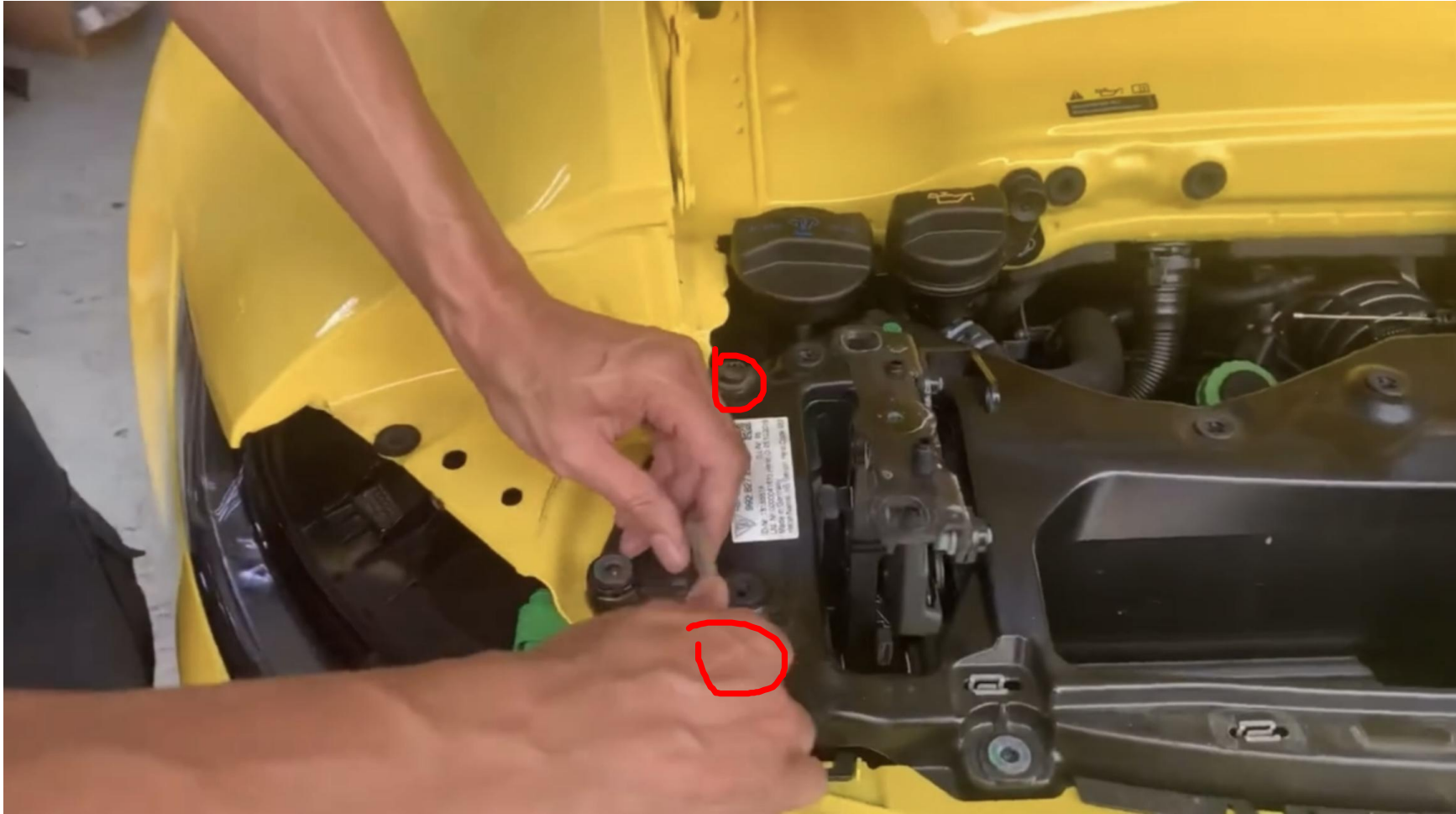

The spoiler base is secured to the car body by four screws, so you need to remove the two screws on each side one by one, as shown in the picture.

Step 10



Slightly lift the clips marked in my picture, one on each side, to detach the spoiler base from the car body.

Step 11

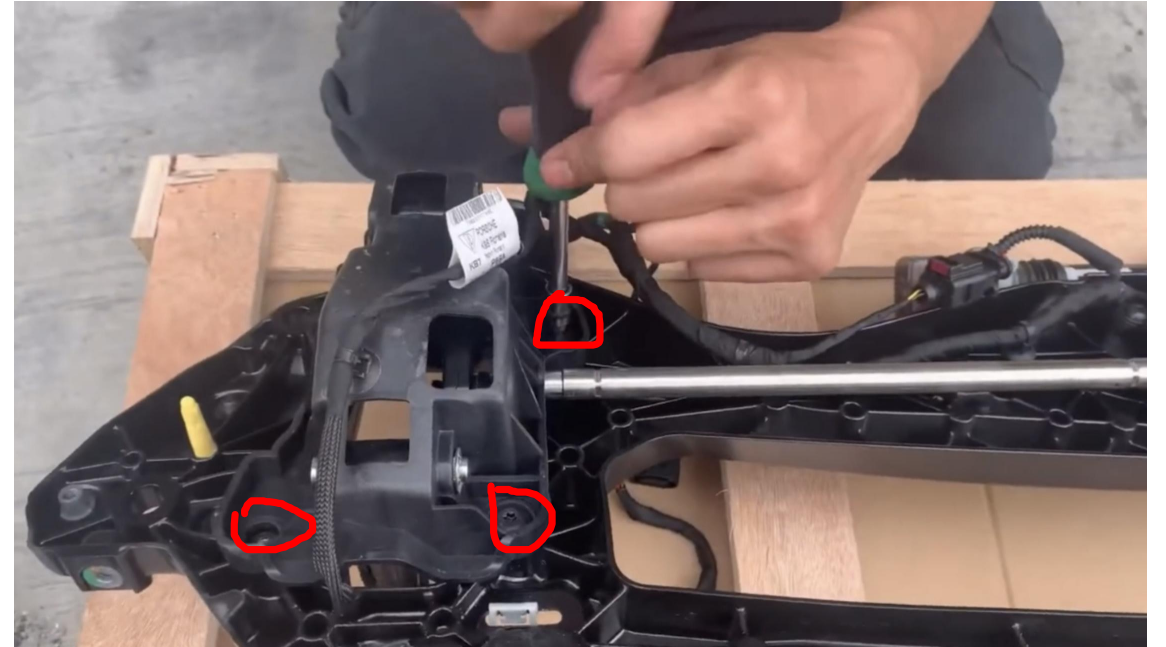
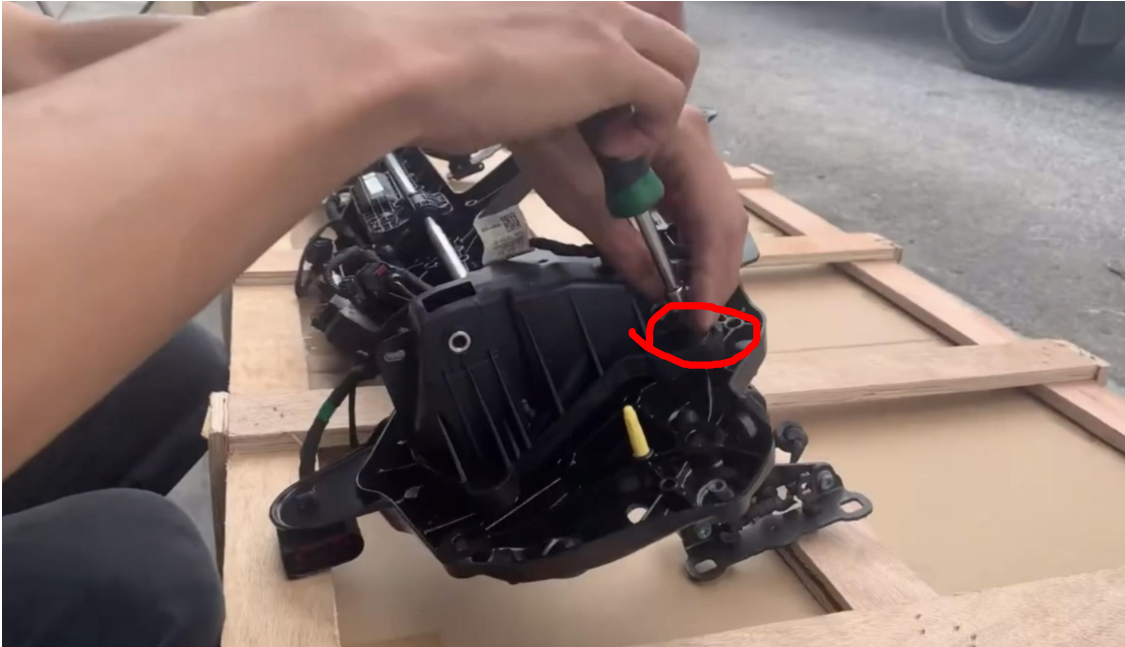

Turn the tail base to the back, and unscrew the four fixed screws on the left and right sides of the lifting mechanism from the back. These four screws need to be left behind, and they need to be reused when installing the duck tail.

Step 12



In the last step, you need to remove the motor and unplug the motor.

Install and secure the spoiler bracket.

Let me first introduce that the tail bracket consists of three parts, A, B, C, and three parts.

The task of the installation part is to install these three parts on the base of the tail

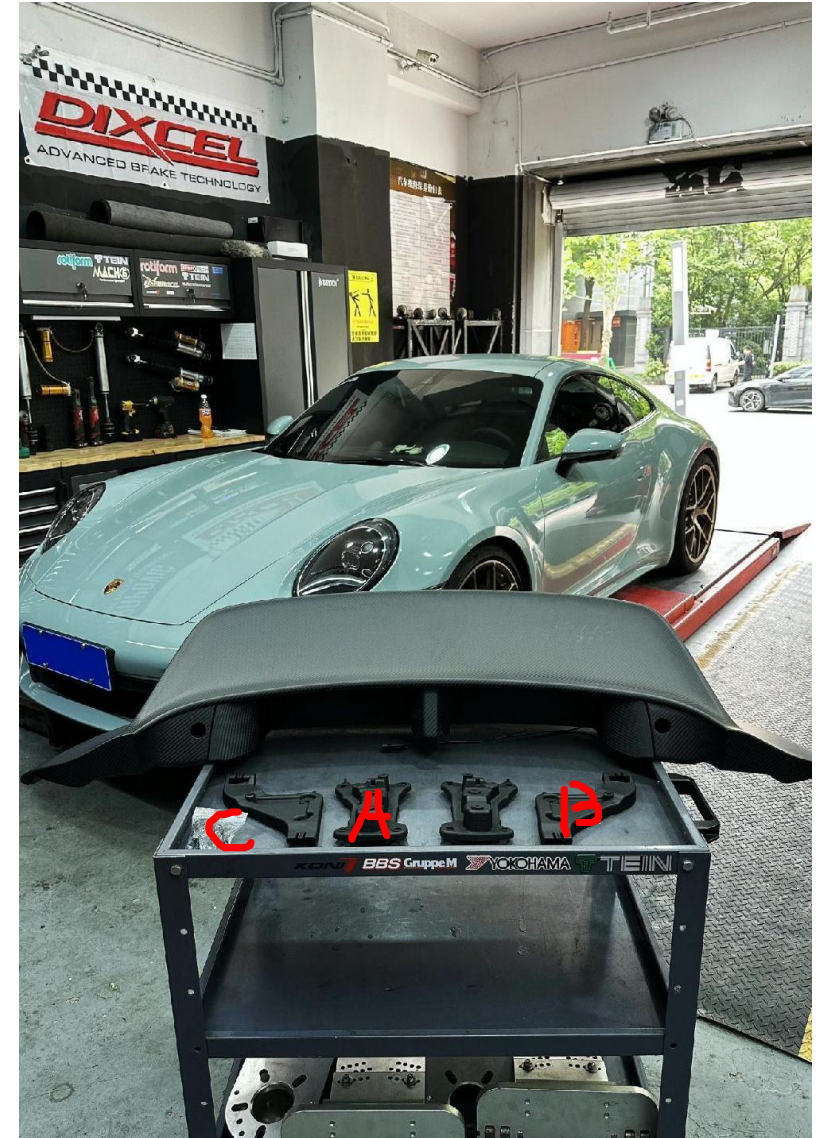



Transform the tail base from the figure above to the figure below,

using the two parts A and B.

Step 1



First of all, you need to remove these four rubber pads, two on the left and one, **be sure to remove them!!!** If they are not removed, the ducktail will sit too high.

Step 2



Install Part A on the tail base, with four screws on the left and right, and the four screws on the left and right that were removed before are just installed.

Step 3

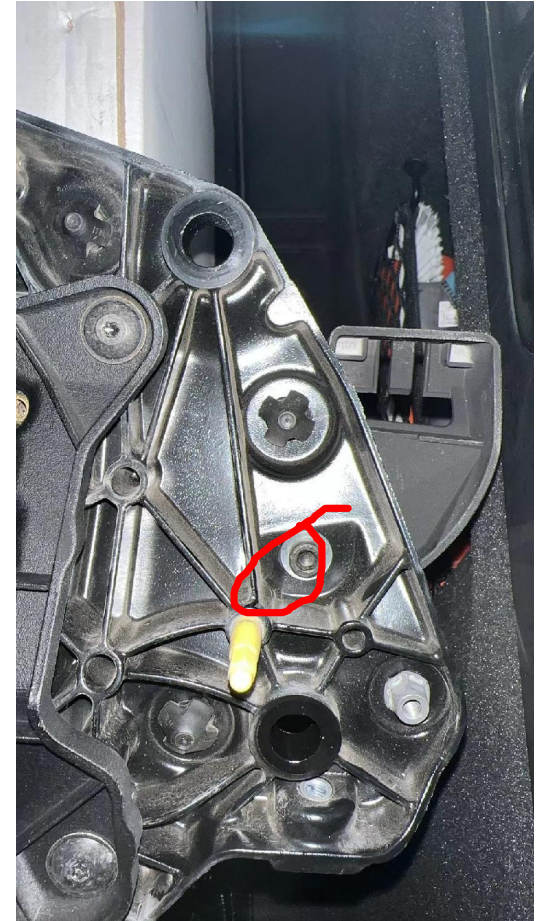
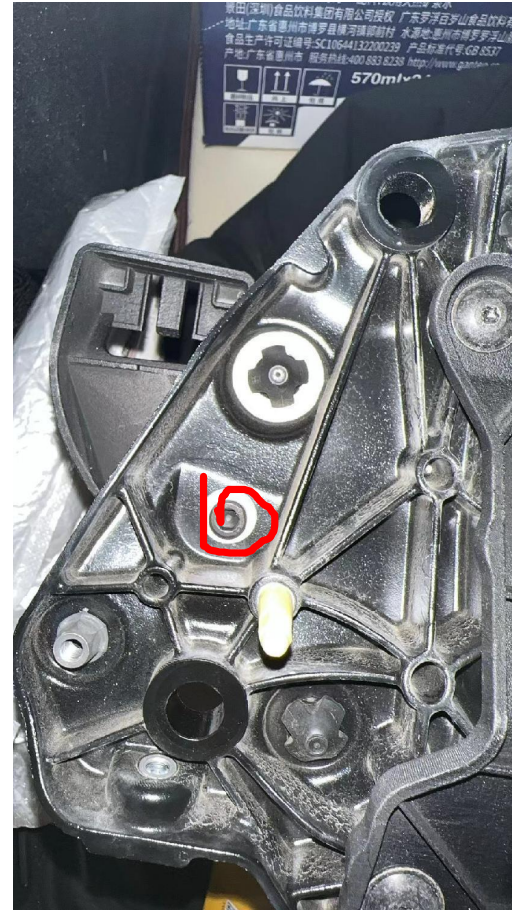

Install PartB as shown in the figure. Two screws on each side are tightened on the front and one screw on the side is tightened on the back. Use the six (6) 20mm M6 screws provided with the kit.

Step 4



Part C installation is shown in the figure.

Step 5



Install all the effects similar to my picture.

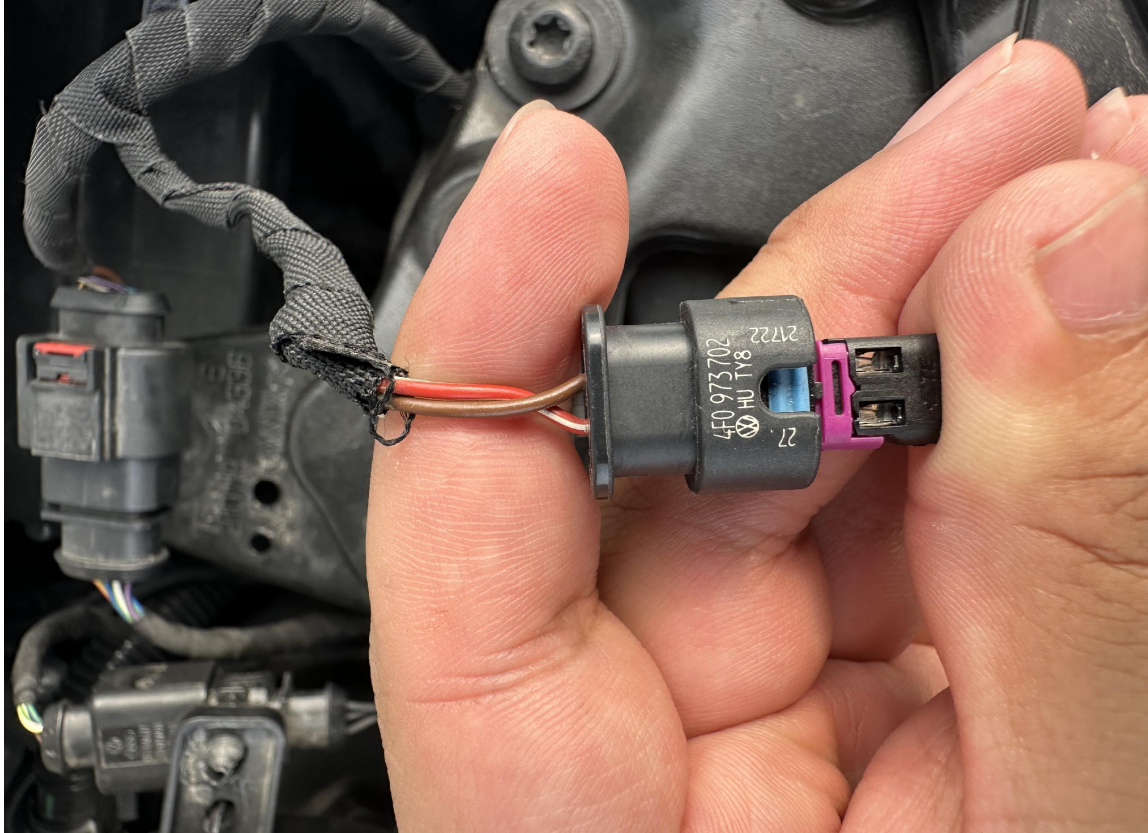

This is the interface of the brake light on my car. Please check whether it is consistent in your car, otherwise you may need to replace it. The brake light socket of the duck tail corresponds to this interface.



If the plug of the brake light on your car is like this, you need to prepare the connector corresponding to this plug in advance and change the connector of the brake light on the ducktail.



To affix the ducktail, use the two screws with the specification M6*40mm. I have put it in the package. There are two screws in total, one on the left and one on the right. Tighten according to the position of the picture

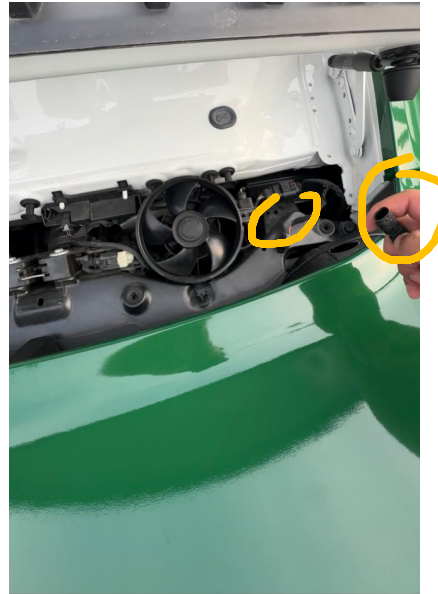

The brake light plug is connected like this.



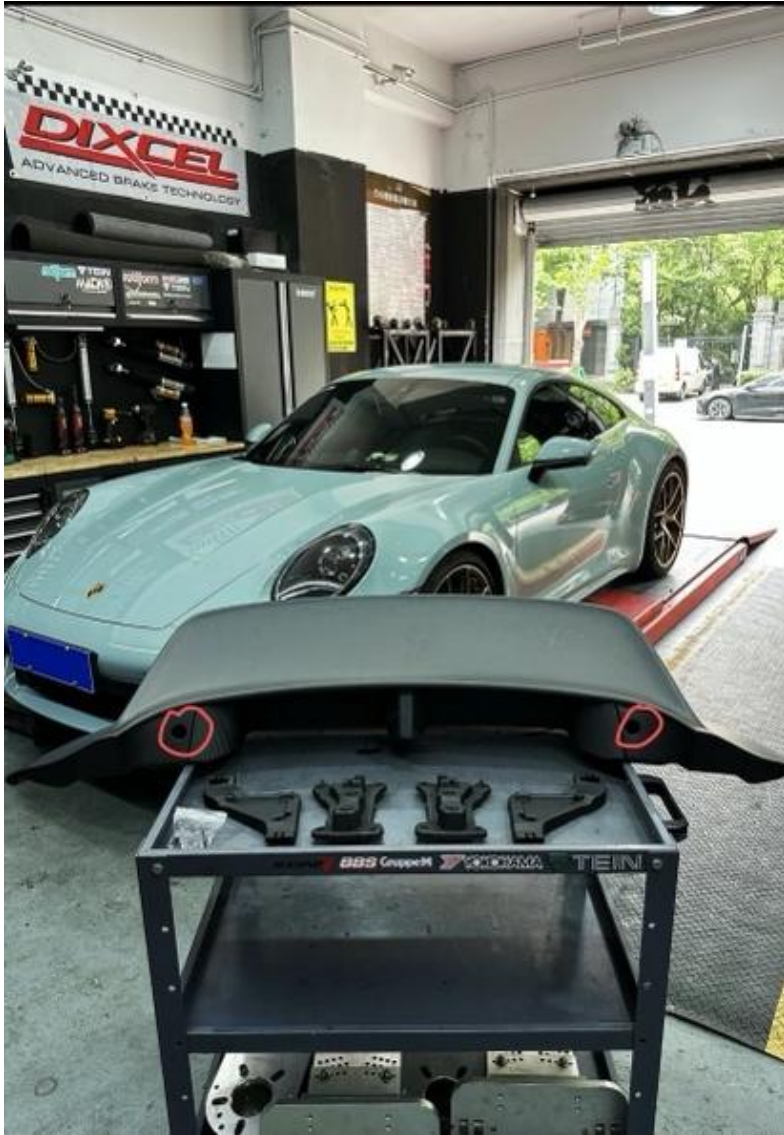

After installing the ducktail, use the two rubber plugs included in the kit to plug the holes shown.